



Reg. No. :

--	--	--	--	--	--	--	--	--	--	--	--	--	--	--	--	--	--	--	--

Question Paper Code : 40044

B.E. DEGREE EXAMINATION, APRIL/MAY 2018

Second Semester

Aeronautical Engineering

GE 8292 : ENGINEERING MECHANICS

(Common to Agriculture Engineering/Automobile Engineering/B.E. Civil Engineering/Environmental Engineering/Industrial Engineering/Industrial Engineering and Management/Manufacturing Engineering/Marine Engineering/Material Science and Engineering/Mechanical Engineering/Mechanical Engineering (Sandwich) /Mechanical and Automation Engineering/ Mechatronics Engineering/Production Engineering/Robotics and Automation Engineering)
(Regulations 2017)

Time : Three Hours

Maximum : 100 Marks

Answer ALL questions.

PART - A

(10×2=20 Marks)

1. Determine the resultant of the three concurrent forces $F_1 = 2i + 3j - 2.5k$, $F_2 = -i + 5j - 3k$, and $F_3 = 7i - 7j + 6k$. The forces are in Newton.
2. State the parallelogram law of forces.
3. Mention the required equilibrium conditions of a body applied with a system of non-concurrent, coplanar forces.
4. A force $F = 6N i - 4j - 5N k$ is acting at a point P whose position vector from the origin O of the coordinate axes is $8 \text{ mm } i + 6 \text{ mm } j - 4 \text{ mm } k$. Find the moment of this force about the origin.
5. What is moment of inertia of triangular lamina ($b \times h$) about its horizontal centroidal axis ?
6. State the parallel axis theorem.



7. Define coefficient of restitution.
8. State the work and energy principle.
9. What is the force F required to just initiate the block shown in figure to slide if the coefficient of friction between the surfaces in contact is 0.4 ?

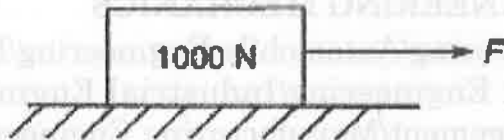

10. A fan rotating at 50 rpm is being switched off and it will come to rest in 20 s. How many revolutions it has made before it comes to rest ?

PART – B

(5×13=65 Marks)

11. a) A transmission tower is held by three guy wires attached to a pin at A and anchored by bolts at B, C, and D. If the tension in wire AB is 3.6 kN, determine the vertical force P exerted by the tower on the pin at A. (13)

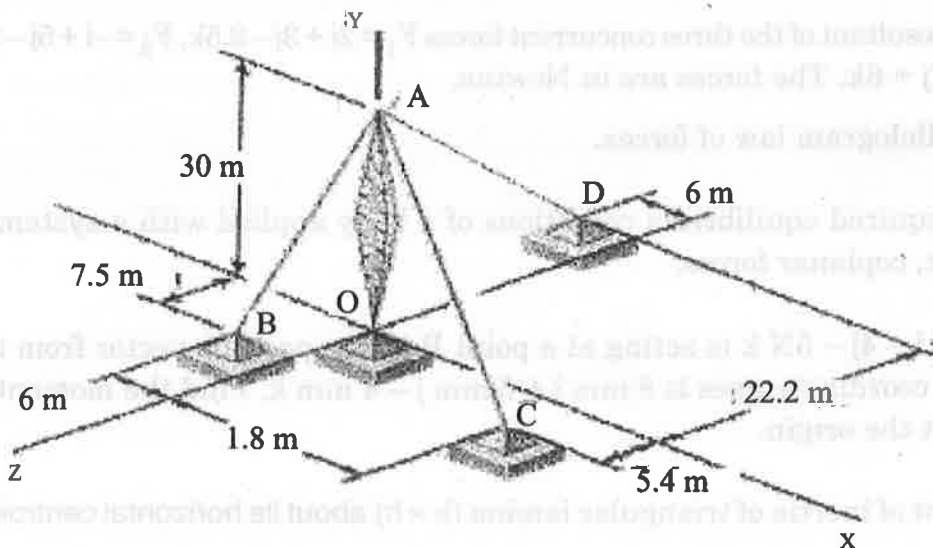

(OR)



- b) Knowing that the tension is 1020 N in cable AB and 850 N in cable AC, determine the magnitude and direction of the resultant of the forces exerted at A by the two cables. (13)

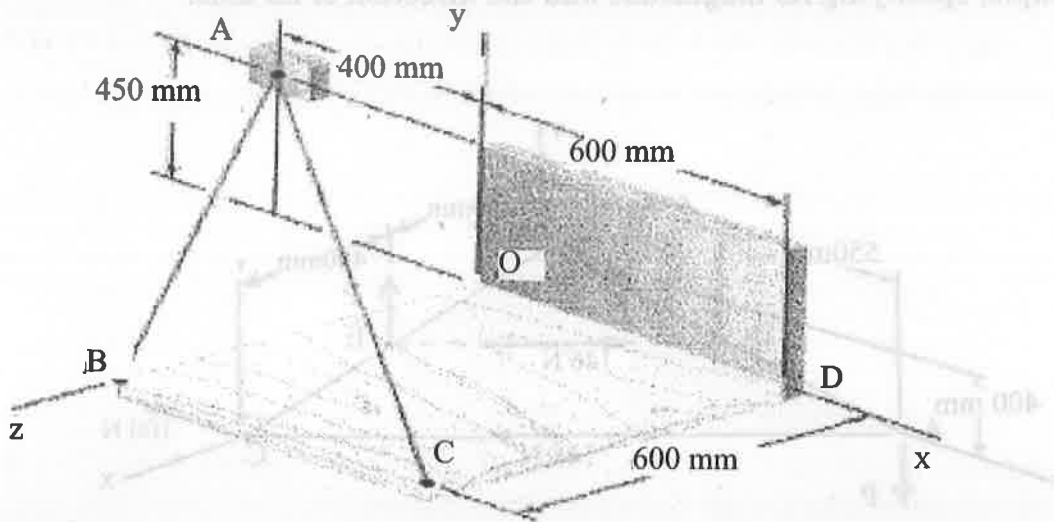

- 12 a) It is known that a vertical force of 800 N is required to remove the nail at C from the board. As the nail first starts moving, determine (a) the moment about B of the force exerted on the nail, (b) the magnitude of the force P which creates the same moment about B if $\alpha = 10^\circ$, (c) the smallest force P which creates the same moment about B. (13)

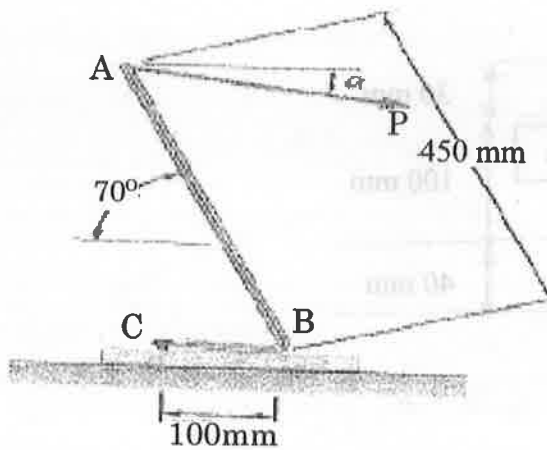

(OR)



- b) Knowing that $P = 210 \text{ N}$, replace the three couples with a single equivalent couple, specifying its magnitude and the direction of its axis. (13)

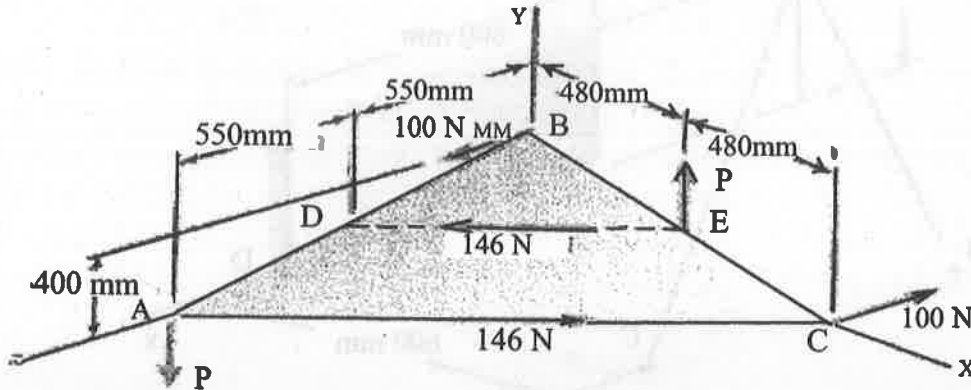

13. a) Determine the center of gravity of the unsymmetrical I section shown in Figure. (13)

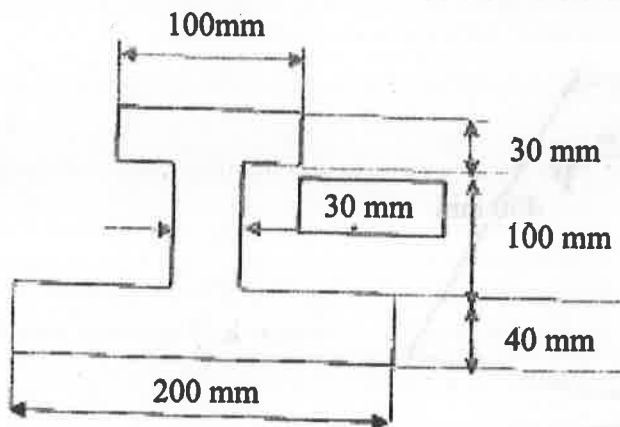

(OR)



- b) Find the moments of inertia about the centroidal axes for the section shown in figure. (13)

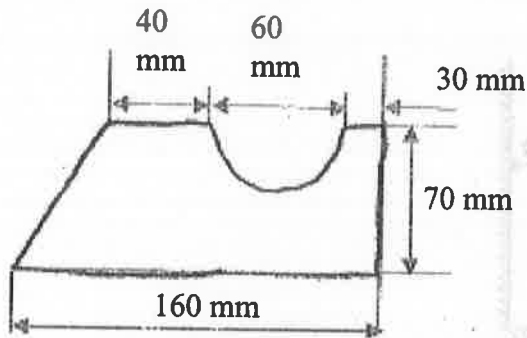

14. a) Two vehicles approach each other in opposite lanes of straight horizontal roadway as shown in Figure. At time $t = 0$, the vehicles have the speeds and positions shown in the figure. Find the time and positions at which the vehicles meet if both continue to move with constant speed. (13)

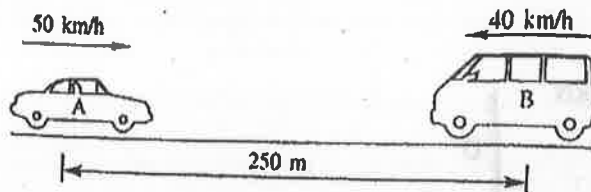

(OR)

- b) A steel ball of weight 60N is dropped onto a spring of stiffness 500 N/m from a height of 100 mm. Find the maximum deflection of the spring (use the work-energy principle). (13)



15. a) Determine the smallest force P required to move the block B if (a) block A is restrained by cable CD as shown in figure. (b) Cable CD removed. Take the coefficients of frictions as $\mu_s = 0.30$, $\mu_k = 0.25$ between all surfaces of contact (13)

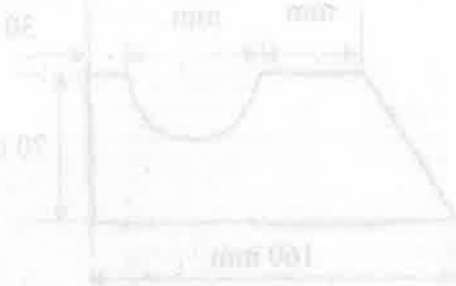
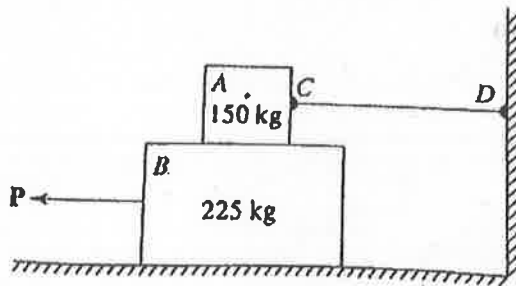

(OR)

- b) Determine the smallest force P required to lift the 13.34 kN load shown in figure. The coefficient of static friction between A and C and B and D is 0.3 and that between A and B is 0.4. (13)

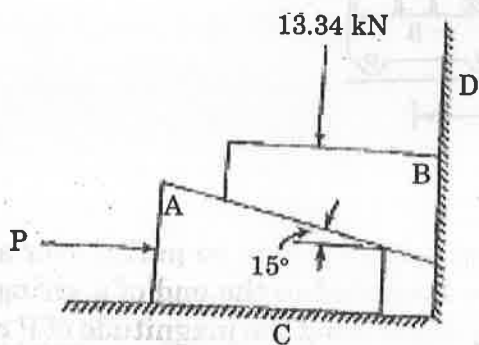



16. a) A camera of mass 240 g is mounted on a small tripod of mass 200 g. Assuming that the mass of the camera is uniformly distributed and that the line of action of the weight of the tripod passes through D, determine
- a) the vertical components of the reactions at A, B and C when $\theta = 0$
 - b) the maximum value of θ if the tripod is not to tip over.

15

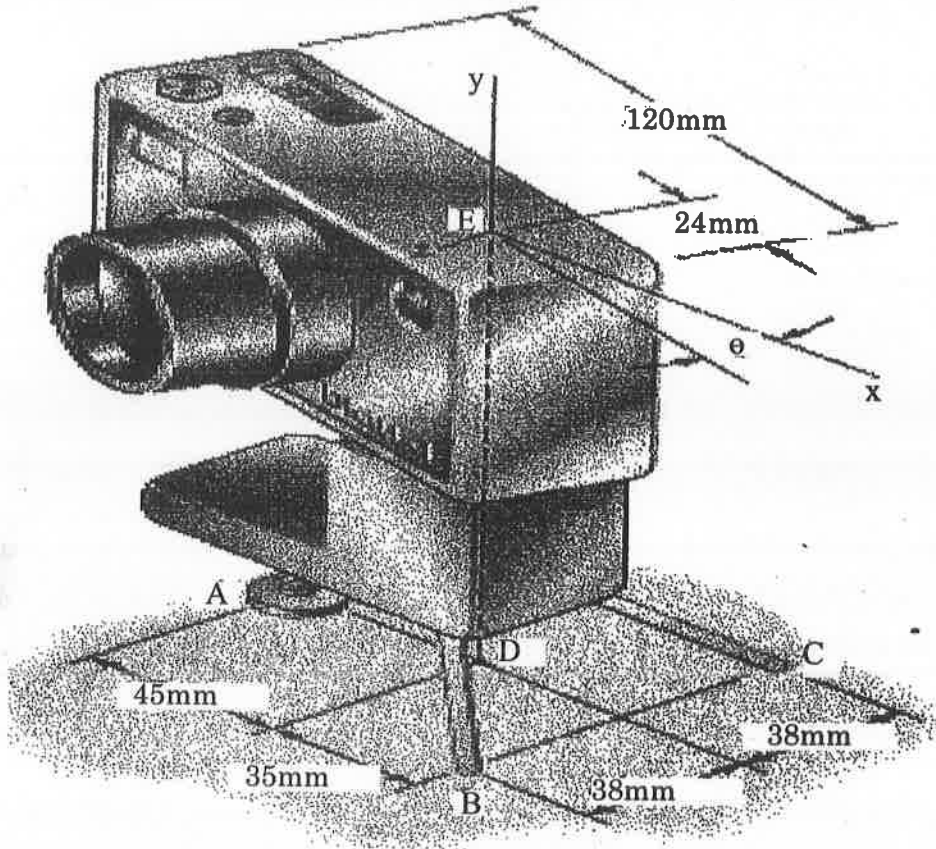

OR

- b) A roller of radius $r = 304.8$ mm and weight = 2225 N is to be pulled over a curb of height $h = 152.4$ mm by a horizontal force P applied to the end of a string wound around the circumference of the roller (Fig. 16(b)). Find the magnitude of P required to start the roller over the curb.

